

# 7700

# 20-Channel, Differential Multiplexer Module

with Automatic CJC, Screw Terminals, and up to 50MHz Bandwidth

- 20 channels for general-purpose measurements, plus two channels to measure current
- Oversize screw terminal connection blocks are standard for easier connections
- 50MHz bandwidth
- 300V, 1A capacity for voltage channels; 60W, 125VA
- 3A capacity for current channels
- Low insertion loss of up to 50MHz
- Relay closures stored in onboard memory



The Model 7700 plug-in module offers 20 channels of 2-pole or 10 channels of 4-pole multiplexer switching that can be configured as two independent banks of multiplexers. There are two additional protected channels for current measurements. Automatic CJC is provided so that no other accessories are required to make thermocouple temperature measurements. In addition, the Model 7700 contains latching electromechanical relays that enable signal bandwidths of up to 50MHz. The Model 7700 is ideal for RTD, thermistor, and thermocouple temperature applications.

## Ordering Information

**7700 20-Ch, Diff Mux Module w/Automatic CJC and Screw Terminals**

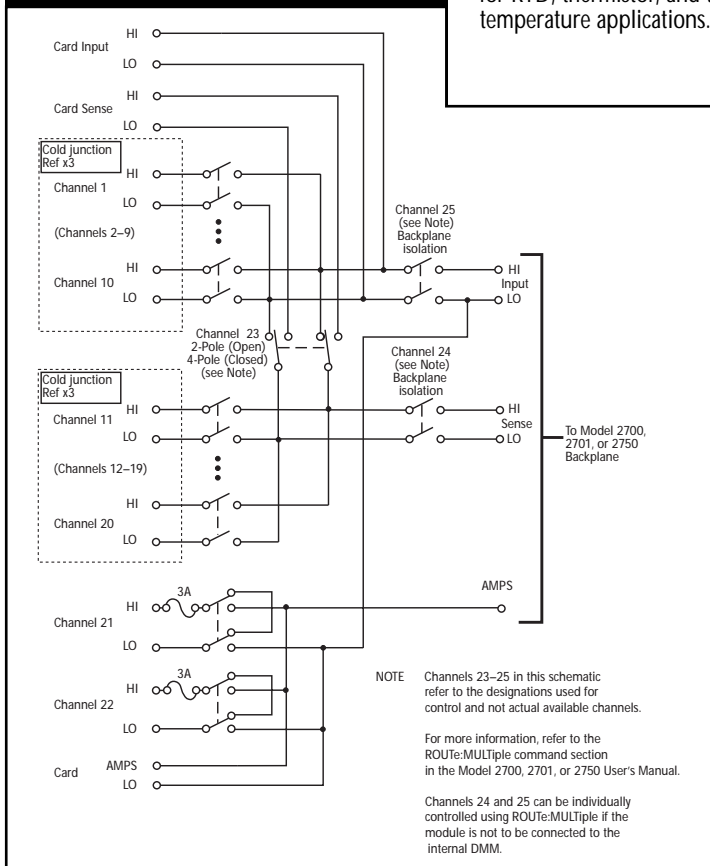

## CAPABILITIES

**CHANNELS 1-20:** Multiplex one of 20 2-pole or one of 10 4-pole signals into DMM.

**CHANNELS 21-22:** Multiplex one of 2 2-pole current signals into DMM.

## INPUTS

### MAXIMUM SIGNAL LEVEL:

**Channels (1-20):** 300V DC or 300V rms (425V peak) for AC waveforms, 1A switched, 60W 125VA maximum.

**Channels (21-22):** 60V DC or 30V rms, 3A switched, 60W 125VA maximum.

**CONTACT LIFE (typ.):** >10<sup>5</sup> operations at max signal level.  
>10<sup>6</sup> operations cold switching.

**CONTACT RESISTANCE:** <1Ω at end of contact life.

**CONTACT POTENTIAL:** <±500nV typical per contact, 1μV max.  
<±500nV typical per contact pair, 1μV max.

**OFFSET CURRENT:** <100pA.

**CONNECTOR TYPE:** Screw terminal, #20 AWG wire size.

**ISOLATION BETWEEN ANY TWO TERMINALS:** >10<sup>10</sup>Ω, <100pF.

**ISOLATION BETWEEN ANY TERMINAL AND EARTH:** >10<sup>10</sup>Ω, <200pF.

### INSERTION LOSS (50Ω Source, 50Ω Load):

	w/Internal DMM	w/o Internal DMM*
<0.1 dB:	1 MHz	1 MHz
<3 dB:	2 MHz	50 MHz

### CROSSTALK (50Ω Load):

	w/Internal DMM	w/o Internal DMM*
10 MHz:	<-40 dB	<-40 dB
25 MHz:	**	<-25 dB

**COMMON MODE VOLTAGE:** 300V or 300V rms (425V peak) for AC waveforms between any terminal and chassis.

**TEMPERATURE ACCURACY USING INTERNAL CJC:** 1.0°C (see mainframe specification for details).

\* Channels 24 and 25 are open. Refer to ROUTe:Multiple command in 27XX User Manual.

\*\* Not valid.

## GENERAL

**20 CHANNELS:** 20 channels of 2-pole relay input. All channels configurable to 4-pole.

**2 CHANNELS:** 2 channels of current only input.

**RELAY TYPE:** Latching electromechanical.

**ACTUATION TIME:** <3ms.

**FIRMWARE:** Specified for Model 2700 rev. A01, 2701 rev. A01, and 2750 rev. A01 or higher.

## ENVIRONMENTAL

**OPERATING ENVIRONMENT:** Specified for 0°C to 50°C.  
Specified to 80% R.H. at 35°C.

**STORAGE ENVIRONMENT:** -25°C to 65°C.

**WEIGHT:** 0.45kg (1 lb).

**ACCESSORY AVAILABLE:** Model 7401 Type K Thermocouple Wire, 30.5m (100 ft).

Use with Integra Series mainframes: 2700, 2701, 2750

DIGITAL MULTIMETERS & SYSTEMS

1.888.KEITHLEY (U.S. only)

www.keithley.com

KEITHLEY

A GREATER MEASURE OF CONFIDENCE